

Michael Shoykhet and Daniel J. Simons

J Neurophysiol 99:356-366, 2008. First published Nov 7, 2007; doi:10.1152/jn.01063.2007

You might find this additional information useful...

This article cites 48 articles, 23 of which you can access free at:

<http://jn.physiology.org/cgi/content/full/99/1/356#BIBL>

Updated information and services including high-resolution figures, can be found at:

<http://jn.physiology.org/cgi/content/full/99/1/356>

Additional material and information about *Journal of Neurophysiology* can be found at:

<http://www.the-aps.org/publications/jn>

This information is current as of January 20, 2009 .

Development of Thalamocortical Response Transformations in the Rat Whisker-Barrel System

Michael Shoykhet and Daniel J. Simons

Department of Neurobiology, University of Pittsburgh School of Medicine, Pittsburgh, Pennsylvania

Submitted 25 September 2007; accepted in final form 5 November 2007

Shoykhet M, Simons DJ. Development of thalamocortical response transformations in the rat whisker-barrel system. *J Neurophysiol* 99: 356–366, 2008. First published November 7, 2007; doi:10.1152/jn.01063.2007. Extracellular single-unit recordings were used to characterize responses of thalamic barreloid and cortical barrel neurons to controlled whisker deflections in 2-, 3-, and 4-wk-old and adult rats in vivo under fentanyl analgesia. Results indicate that response properties of thalamic and cortical neurons diverge during development. Responses to deflection onsets and offsets among thalamic neurons mature in parallel, whereas among cortical neurons responses to deflection offsets become disproportionately smaller with age. Thalamic neuron receptive fields become more multiwhisker, whereas those of cortical neurons become more single-whisker. Thalamic neurons develop a higher degree of angular selectivity, whereas that of cortical neurons remains constant. In the temporal domain, response latencies decrease both in thalamic and cortical neurons, but the maturation time-course differs between the two populations. Response latencies of thalamic cells decrease primarily between 2 and 3 wk of life, whereas response latencies of cortical neurons decrease in two distinct steps—the first between 2 and 3 wk of life and the second between the fourth postnatal week and adulthood. Although the first step likely reflects similar subcortical changes, the second phase likely corresponds to developmental myelination of thalamocortical fibers. Divergent development of thalamic and cortical response properties indicates that thalamocortical circuits in the whisker-to-barrel pathway undergo protracted maturation after 2 wk of life and provides a potential substrate for experience-dependent plasticity during this time.

INTRODUCTION

The mammalian brain is immature at birth and remains so for a protracted postnatal period. During this time, experience permanently impacts the structural and/or functional development of central neuronal circuits, often with specific behavioral consequences. Understanding normal developmental sequences may yield valuable insights into the nature of adult circuitry and its experience-dependent modifications. Sensory systems have received considerable experimental attention in this regard, because circuit function can be probed using natural stimuli and because the neonatal sensory environment can be explicitly manipulated (Hubel and Wiesel 1962; Wiesel and Hubel 1963). Numerous studies in a variety of species, including humans, have shown that the visual system, particularly its geniculocortical component, is strongly influenced by visual experience throughout a defined postnatal period, during which thalamocortical circuits are still developing their adult-like form (Hubel et al. 1977; LeVay et al. 1980; von Senden 1960). Such phenomena are thought to extend to neuronal

systems mediating other perceptual and cognitive functions (Curtiss 1982; Harlow et al. 1965).

Over the past 20 yr, the rodent somatosensory system has emerged as an important model for studying experience-dependent plasticity and development. Like the visual system, the rodent whisker-to-barrel pathway is immature at birth (Van der Loos and Woolsey 1973) and is subject to extensive experience-dependent modification with observable behavioral consequences. For example, simple whisker trimming during the first few postnatal weeks leads to permanent abnormalities in cortical responses to regrown whiskers (Shoykhet et al. 2005; Simons and Land 1987a) and to deficits in whisker-based tactile discriminations (Carvell and Simons 1996). Because thalamic receptive fields are largely unaffected by neonatal whisker trimming (Simons and Land 1994), effects in layer IV whisker-related barrels may reflect altered thalamocortical circuits. In addition, the rodent somatosensory system possesses a unique advantage of being amenable to analyses at multiple levels—from genetic and molecular studies to in vitro and in vivo experiments. However, the normal development of neuronal responses to sensory stimuli in the rodent thalamocortical circuit has not been characterized, perhaps because of technical difficulties of conducting neurophysiologic studies in vivo in young animals. In normal adult animals, response properties differ between thalamic neurons and their postsynaptic targets in cortical layer 4 (Simons and Carvell 1989). It is presently unknown how these transformations develop and to what extent receptive field development relates to the susceptibility of the system to whisker experience.

To date, only a handful of studies have examined responses of neurons in the developing whisker/barrel system to tactile stimuli in vivo. At the level of the trigeminal ganglion (NVg), primary afferent neurons display qualitatively single-whisker receptive fields before birth (Chiaia et al. 1993). Quantitative single-unit recordings of NVg neurons in 2- to 4-wk-old animals, however, showed that, although NVg neurons in maturing animals, as in adults, possess single-whisker receptive fields, they continue to develop adult-like response latencies and magnitudes during this time and continue to fine-tune their angular tuning (Shoykhet et al. 2003). At the cortical level, single-unit recordings in 7-day-old rats under urethane anesthesia revealed low spontaneous activity, inability to follow stimuli >1 every 15 s, and receptive fields (RFs) considerably larger than those in adult animals (Armstrong-James 1975). Multiunit recordings in layer IV of the somatosensory cortex in postnatal day 2 (P2) to P14 rats, however, showed

Address for reprint requests and other correspondence: D. J. Simons, E1452 Biomedical Science Tower, Dept. of Neurobiology, Univ. of Pittsburgh School of Medicine, Pittsburgh, PA 15261 (E-mail: cortex@pitt.edu).

The costs of publication of this article were defrayed in part by the payment of page charges. The article must therefore be hereby marked “advertisement” in accordance with 18 U.S.C. Section 1734 solely to indicate this fact.

small RFs even during the first 4 postnatal days (McCandlish et al. 1993). More recently, Stern et al. (2001) recorded intracellularly from several layer IV neurons in 12–20 day old rat pups *in vivo*. Consistent with previous results, they found that neurons in layer IV responded with action potentials to whisker movements at 12 days of age and that the strongest responses were elicited by deflections of the principal whisker (PW). These studies, while providing a qualitative assessment of RF properties, focused solely on cortical activity and were not designed to address the issue of how immature central circuits in the whisker-to-barrel pathway process and transform their sensory input.

To study the development of thalamocortical response transformations, we recorded in separate experiments from VPM barreloid and from layer IV barrel neurons in rats at 2, 3, and 4 wk of age and in adulthood. Direct comparison between thalamic and cortical responses allows for examining the development of response transformations in this system. Results indicate that response properties of thalamic and cortical neurons diverge during development with respect to response magnitude, directional tuning, RF focus on the PW, and response timing. These changes likely reflect the maturation of the thalamocortical and intracortical circuits and confirm, as suggested previously (Shoykhet et al. 2005), that the rodent somatosensory system continues to mature well beyond the onset of active whisking at the end of the 2nd postnatal week. We propose that continuing development between P14 and adulthood provides one of the substrates for experience-dependent persistent modification of sensory information processing and behavior observed in the whisker-to-barrel pathway.

METHODS

Animals

Sprague-Dawley rats of 13–15, 20–22, 27–29, and >65 days of age were used for the experiments (day of birth = P0). These age groups are denoted P14, P21, P28, and P65, respectively. For cortical recordings, the subject cohort consisted of 13 P14, 15 P21, 9 P28, and 8 P65 animals. For thalamic recordings, five P14, four P21, and four P28 rats were used. Thalamic data from P65 rats ($n = 19$) were taken from an earlier study (Simons and Carvell 1989). Pups were from dams with litters born on specified dates (Harlan Sprague-Dawley, Indianapolis, IN) and were housed with their mothers throughout. All procedures were approved by the Institutional Animal Care and Use Committee.

Surgical procedures and maintenance

Surgical procedures were previously described in adult animals (Simons and Carvell 1989) and were adapted for neonatal rats (details of the procedures are available at <http://www.neurobio.pitt.edu/barrels/>). The explicit goal was to minimize procedural differences between adult and neonatal animals and to create experimental conditions that differ little between this study and previous ones in our laboratory investigating thalamocortical response transformations in adult animals. Briefly, under halothane anesthesia, the external jugular vein and the femoral artery were catheterized, and a tracheotomy was performed. Recordings were obtained from the right hemisphere. The skull was exposed, and a steel post was fixed to the bone with stainless steel screws (also used for electroencephalographic recordings), cyanoacrylate, and dental acrylic. The post was used to hold the animal's head without ear bars or other pressure points during the experiment. Skull overlying the region of interest was thinned by drilling, and a craniotomy ($\approx 2 \text{ mm}^2$ for thalamic recordings, $\approx 0.5 \text{ mm}^2$ for cortical

recordings) was performed. For all thalamic recordings, an acrylic well was constructed around the craniotomy site, and the exposed dura was kept moist with physiologic saline. For cortical recordings in P14 and P21 animals, spatial constraints precluded construction of the acrylic dam. Instead, the temporalis muscle was apposed to the craniotomy edge, and the dura was preserved and kept moist by periodic application of saline. For cortical recordings in P28 and P65 animals, the dam was constructed, and the dura was carefully incised. Cerebral vasculature served as a landmark for locating the barrel field in young animals, since during development, brain nuclei shift posteriorly and laterally with respect to skull landmarks (Sherwood and Timiras 1970).

After the completion of surgical procedures, the animal was transferred to a vibration isolation table, the arterial line was connected to a pressure monitor (WPI, Sarasota, FL), and the venous line to two continuous infusion pumps (Razel, Stamford, CT). Neuromuscular blockade was induced with a bolus dose of pancuronium bromide ($\approx 1.0 \text{ mg/kg}$) and maintained with a continuous infusion of 1.6 mg/kg/h . Rats were respired with a 50/50 O_2/N_2 mixture using a MiniVent ventilator (Harvard Apparatus, Cambridge, MA) for P14 and P21 animals and an Inspira ventilator (Harvard Apparatus) for the older rats. Halothane was discontinued, and for the rest of the experiment, the animal was maintained in a sedated, lightly narcotized state using continuous infusion of a synthetic opiate, fentanyl ($\approx 10 \mu\text{g/kg/h}$). Core body temperature was kept constant at 37°C by means of a servo-controlled heating blanket (Harvard Apparatus) and a DC-powered 20-W halogen lamp.

To assess the rat's physiological condition during the recording experiment, we continuously monitored mean arterial blood pressure (MAP), pulse rate, tracheal airway pressure waveform including peak end inspiratory pressure (PEIP), capillary perfusion of glabrous skin, and pupillary reflexes. As in other mammals, MAP increases during development (e.g., 45–50 mmHg for P14, 110–125 mmHg for adult), making the use of an absolute MAP value impractical as an objective criterion of the adequacy of the animal's physiological state. In preliminary studies, we found that halothane anesthesia lowers MAP by 15–30 mmHg. Therefore if MAP failed to rise on discontinuation of halothane, or if it fell below the halothane value during the recording session, the experiment was terminated. Preliminary studies also indicated that increases in PEIP above 15 cm H_2O were associated with significant damage to lung tissue in young animals; experiments were terminated if PEIP exceeded this value.

Single-unit recording and whisker stimulation

Extracellular single-unit recordings from thalamic neurons in all age groups and from cortical neurons in P14 and P21 animals were obtained with stainless steel microelectrodes (6- to 8-M Ω impedance at 1 kHz for thalamic recordings and 4- to 6-M Ω impedance at 1 kHz for cortical recordings; FHC, Bowdoinham, ME). In the cortex of P28 and P65 animals, single-unit recordings were obtained with double-barrel glass microelectrodes (6- to 8-M Ω impedance at 1 kHz). One barrel contained 3 M NaCl as a recording solution, and the other contained 10% wt/vol solution of horseradish peroxidase (HRP) in 50 mM Tris (hydroxymethyl)aminomethane HCl buffer (pH 6.8) for reconstructions of electrode tracks (Simons and Land 1987b). Glass microelectrodes require removal of dura mater, which we wanted to avoid during cortical recordings in young animals. Steel microelectrodes easily penetrate the dura and provided satisfactory isolation of single units in layer IV of young animals but less so in P28 and adult rats, perhaps because of denser neuropil. Both metal microelectrodes in young rats and glass microelectrodes in older animals readily distinguish between cortical regular-spike (RSU) and fast-spike units (FSUs) when the signal is appropriately filtered (Bruno and Simons 2002). Cortical recordings were targeted to layer IV, whose approximate depth in each age group was determined in a series of preliminary experiments.

Single units were identified on the basis of spike amplitude and waveform criteria and isolated using a time-amplitude window discriminator (Bak Electronics, Germantown, MD). Once a unit was isolated, the whisker that elicited the most robust response, i.e., the PW was identified by manual stimulation. The PW and up to four of its cardinally adjacent whiskers (AWs; rostral, caudal, dorsal, and ventral) were deflected sequentially using multiangle piezoelectric stimulators (Simons 1983). The stimulators were attached 5 mm from the face and produced 0.5-mm amplitude deflections at the tip during cortical recordings in all age groups and during thalamic recordings in 2-, 3-, and 4-wk-old animals. During thalamic recordings in adults and in previous studies from this laboratory (Bruno and Simons 2002; Simons and Carvell 1989), the stimulators were attached 10 mm away from the face and delivered a 1-mm deflection. The angular deflection amplitude ($\approx 5.7^\circ$) was thus equivalent in all age groups. The piezoelectric stimulators were additionally calibrated with a photo-diode circuit to deliver a similarly shaped deflection regardless of amplitude.

Each whisker was deflected in eight directions in 45° increments (caudal = 0° , dorsal = 90°). PW deflections were repeated 10 times for a total of 80 deflections per whisker (10×8 directions); AW deflections were repeated 5 or 10 times. Deflections were delivered in a random sequence at 3-s intervals in P14, P21, and P28 animals and at 2-s intervals in adults. Data were collected for 500-ms bracketing a 200-ms ramp-and-hold stimulus. Spike times were collected with 100- μ s resolution, and spike waveforms corresponding to these event times were digitized at 32 kHz using a PCI-MIO-16E4 data acquisition board (National Instruments, Austin, TX) controlled by custom-written LabVIEW software. On-line representations of obtained responses were processed via a DDE link between LabVIEW and Microsoft Excel. If several units with distinctly different waveforms were recorded simultaneously, waveforms were sorted off-line using MCLUST v2.0 (A. David Redish) or custom-written programs.

Histology

At the end of the recording session, electrode location during the last penetration was marked by either an electrolytic lesion or HRP ejection. During thalamic recordings, electrolytic lesions were placed at the termination of electrode tracks, deep to VPm in the forearm representation of the ventral posterolateral nucleus. During cortical recordings in P14 and P21 animals, an electrolytic lesion was placed at or 100–200 μ m below the location of the last recorded cortical neuron. During cortical recordings in P28 and P65 rats, HRP was microiontophoretically ejected through the electrode tip at infragranular sites on the last penetration (Simons and Land 1987b). At the end of the recording session, the rat was deeply anesthetized with halothane until MAP fell well below the value observed during surgery, and the animal was perfused transcardially with heparinized saline followed by fixative for cytochrome oxidase histochemistry. The brains were cryoprotected in 30% wt/vol sucrose/0.1 M phosphate buffer for 24 h.

For identification of thalamic recording locations, the brains were cut coronally in 60- μ m sections and stained with thionin. Electrode tracks and lesion locations were identified; recording depths were reconstructed from microdrive readings during the experiment and lesion locations. Only data collected from recording sites in VPm are included in the analyses; no attempt was made to assign neurons to individual, anatomically defined barreloids.

For identifying cortical recording sites, the right cortical hemispheres were dissected, slightly flattened, and sectioned into 60- μ m slices in the tangential plane. Sections from P14 and P21 animals were reacted for CO (Wong-Riley et al. 1978) and counterstained with thionin. Sections containing layers I–IV from P28 and P65 animals were similarly processed, whereas sections containing layers V–VI and HRP deposits located therein were reacted for HRP (Simons and Land 1987b). Locations of electrode penetrations with respect to CO-rich barrel centers were reconstructed from visualization of elec-

trode tracks and electrolytic lesions or HRP marks. Laminal location of recorded neurons was inferred from microdrive readings during the experiment and laminal location of the lesion or the HRP spot. Only units localized to cytochrome oxidase-rich barrel centers are included in the analyses.

Data analyses

For data analyses, spike time-stamps were converted to peristimulus time histograms (PSTHs) with 1-ms resolution. For quantifying responses to whisker deflection, onset (ON) and offset (OFF) 25-ms time windows were determined by examining population PSTHs compiled for PW deflections over all deflection angles. ON and OFF response magnitudes are reported as spikes per 25 ms. Spontaneous activity and firing rates during sustained whisker deflection (plateau responses) were determined from 100-ms epochs and are reported in spikes per second. Plateau activity was measured from the deflection angle evoking the largest response during the latter part of the sustained whisker deflection. Neurons were designated as slowly adapting (SA) if plateau activity evoked at this deflection angle exceeded spontaneous activity (*t*-test, 1-tailed $P < 0.05$; see Simons and Carvell 1989).

Neurons were included in all analyses if deflection of the PW generated a statistically significant response and if responses for at least one AW were also separately collected. A response was defined as statistically significant if it exceeded spontaneous activity on either one of the following two measures. 1) ON responses were examined to identify the deflection angle evoking the largest number of spikes (ON_{max}), and ON_{max} was compared with mean spontaneous activity (*t*-test, 1-tailed $P < 0.025$). 2) PSTHs were examined to identify the deflection angle evoking the largest number of spikes in any one bin during the ON response, and the value of this bin was compared with that of 100 bins during spontaneous activity using a Poisson distribution ($P < 0.025$); the first significant bin at this deflection angle was also taken as response latency. The first measure is sensitive to temporally distributed responses, whereas the second is sensitive to temporally focused responses. The use of the two measures thus maximized the likelihood of identifying AW responses, making potential differences between thalamic and cortical populations more robust.

Time to 50th percentile spike (T50) was computed for each unit as the time required to discharge 50% of the spikes in a 25-ms epoch beginning with the first PSTH bin to exceed spontaneous activity ($P < 0.025$) (Brumberg et al. 1999). Directional selectivity was evaluated using the ratio of response magnitude at the preferred direction to response magnitude averaged over all deflection angles (ON_{max}/ON_{mean}).

Statistical treatment of data

Neuronal responses in young animals, especially those from cortical neurons, are less robust and more variable than those in adult animals, which results in greater variance around a smaller mean. Under these circumstances, an outlier can significantly shift the computed mean of the sample away from the true population mean. To minimize the impact of outliers on the calculated mean, α -trimmed means were used to compare average values among different age groups (Fisher and van Belle 1993). Trimmed means are calculated on the sample from which the $k \times n$ smallest and largest value observations are removed; k is the next integer greater than or equal to $\alpha \times n$, and n is the number of observation in the sample. 0.05 – trimmed means were used in this study, which would result in the removal of the two largest and two smallest observations from a sample of 40. This technique makes means and comparisons among them more robust by 1) reducing the degrees of freedom and 2) taking into account only the more frequently observed values in the distribution. ANOVA and Student's *t*-test become more conservative with α -trimmed means, being less likely to find a difference between the

two true population means than the same tests using untrimmed means (Fisher and van Belle 1993). Previously collected adult thalamic data (Simons and Carvell 1989) were subjected to the same trimming procedure with minimal to no changes in the sample means.

Standard statistical tests (e.g., ANOVA, Student's *t*-test) were used for parametric analyses. The nonparametric Kruskal-Wallis (K-W) ANOVA or Mann-Whitney two-sample test was used when the assumption of homogeneity of variance was violated. Distributions of discrete variables (e.g., RF size) were compared using a χ^2 test (Siegel 1956). Differences were considered statistically significant if two-tailed probability values were <0.05 . When required, probability values were corrected for multiple comparisons using the Bonferroni method.

RESULTS

Only data from cortical neurons in cytochrome oxidase-rich barrel centers in layer IV of primary somatosensory cortex and from thalamic neurons located in VPM barreloids are presented in the analyses. In P14, P21, P28, and P65 animals, we recorded from 34, 63, 41, and 51 RSUs in the cortex, respectively, and from 39, 35, 36, and 135 thalamocortical units (TCUs) in VPM, respectively.

Thalamic and cortical responses develop along different trajectories. Figure 1A shows population PSTHs of responses of thalamic neurons at different ages. The thalamic PSTH at P14 shows more widely dispersed ON and OFF responses, whereas beginning at P21, PSTHs are temporally focused and nearly adult-like in shape. In the cortex, on the other hand, responses continue to undergo development at later ages (Fig. 1B). As in adults, in developing animals, cortical responses are of smaller magnitude than thalamic responses (Fig. 1C).

Response magnitudes

Responses to different stimulus components are quantified in Fig. 2. ON and OFF responses of thalamic neurons develop in parallel (Fig. 2A). VPM ON responses increase between P14 and P21 from 1.29 ± 0.64 to 1.63 ± 0.76 (SD) spikes/stimulus, remain essentially unchanged between P21 and P28 (1.64 ± 0.68 spikes/stimulus), and decrease to 1.03 ± 0.36 spikes/stimulus in adult animals (KW, $P < 0.0001$). Group-by-group comparisons indicate that the age-dependent increase in VPM ON responses between P14 and P21 is significant at a trend level (MW, $P = 0.06$ with Bonferroni correction). The decrease in average thalamic ON response magnitude between P28 and P65 is statistically significant (MW; $P < 0.0001$ with Bonferroni correction). These data suggest that development of evoked ON response magnitudes in thalamic neurons follows an inverted U trajectory. The initial increase appears to parallel changes in trigeminal ganglion cell responses (see DISCUSSION).

Thalamic OFF response magnitudes, like those of ON responses, increase between P14 and P21 from 0.96 ± 0.58 to 1.40 ± 0.72 spikes/stimulus and decrease to 0.89 ± 0.40 spikes/stimulus in adulthood (KW, $P = 0.007$). Comparison of average OFF responses at individual ages indicates that the increase in magnitude observed between P14 and P21, as well as the decrease in magnitude between P28 and P65, are both statistically significant (MW, $P = 0.04$ and $P = 0.01$ with Bonferroni correction). Therefore ON and OFF responses of thalamic neurons change in parallel during development, increasing during the third postnatal week and decreasing to adult values after the first month of life.

In contrast to thalamic responses, cortical ON and OFF response magnitudes diverge during development (Fig. 2B). RSU

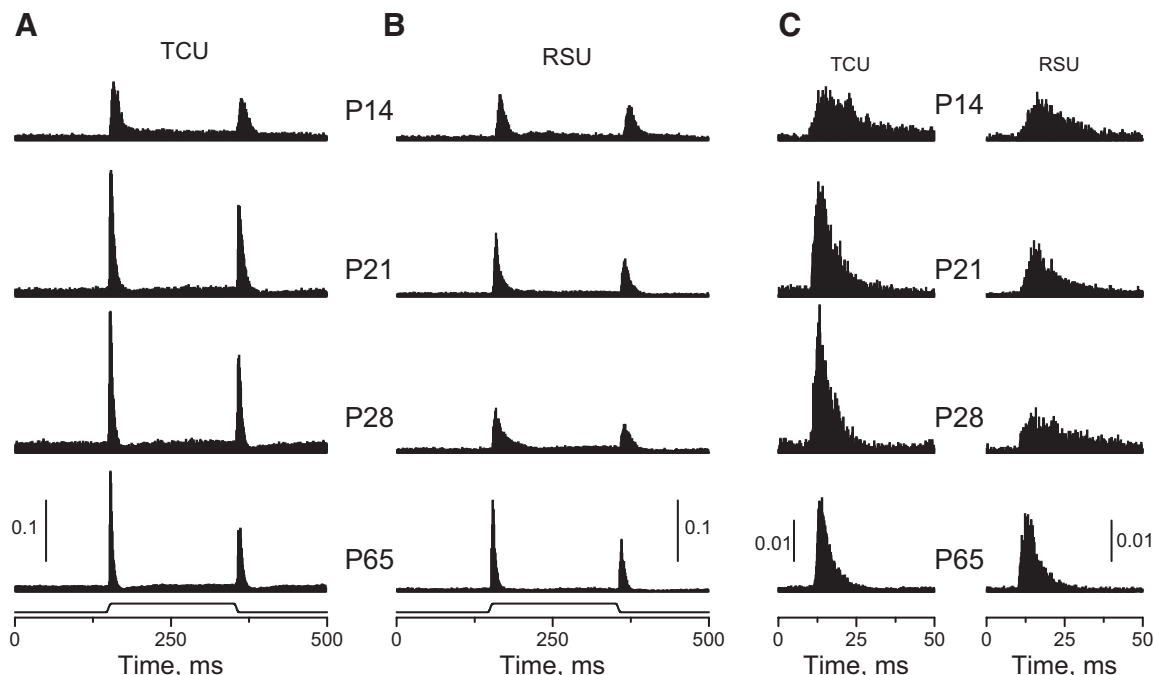

FIG. 1. Population peristimulus time histograms (PSTHs) of thalamic and cortical responses to whisker deflections during development. *A*: responses of thalamocortical units (TCUs) to a 200-ms-long ramp and hold stimulus accumulated over all deflection angles. The age groups are indicated to the right of the histograms. Stimulus waveform is shown as the bottom tracing. Scale bar indicates probability of observing a spike in a 1-ms bin and applies to all age groups. *B*: responses of regular-spike units (RSUs). Note that the scale is identical to that used for TCU PSTHs. *C*: ON response PSTHs for TCUs (left) and RSUs (right) in 100- μ s bins. PSTHs start 10 ms before the ON response in each age group. The scale bar indicates probability of observing a spike in each 100- μ s bin. Note age-related changes in temporal dispersion of TCU and RSU ON responses.

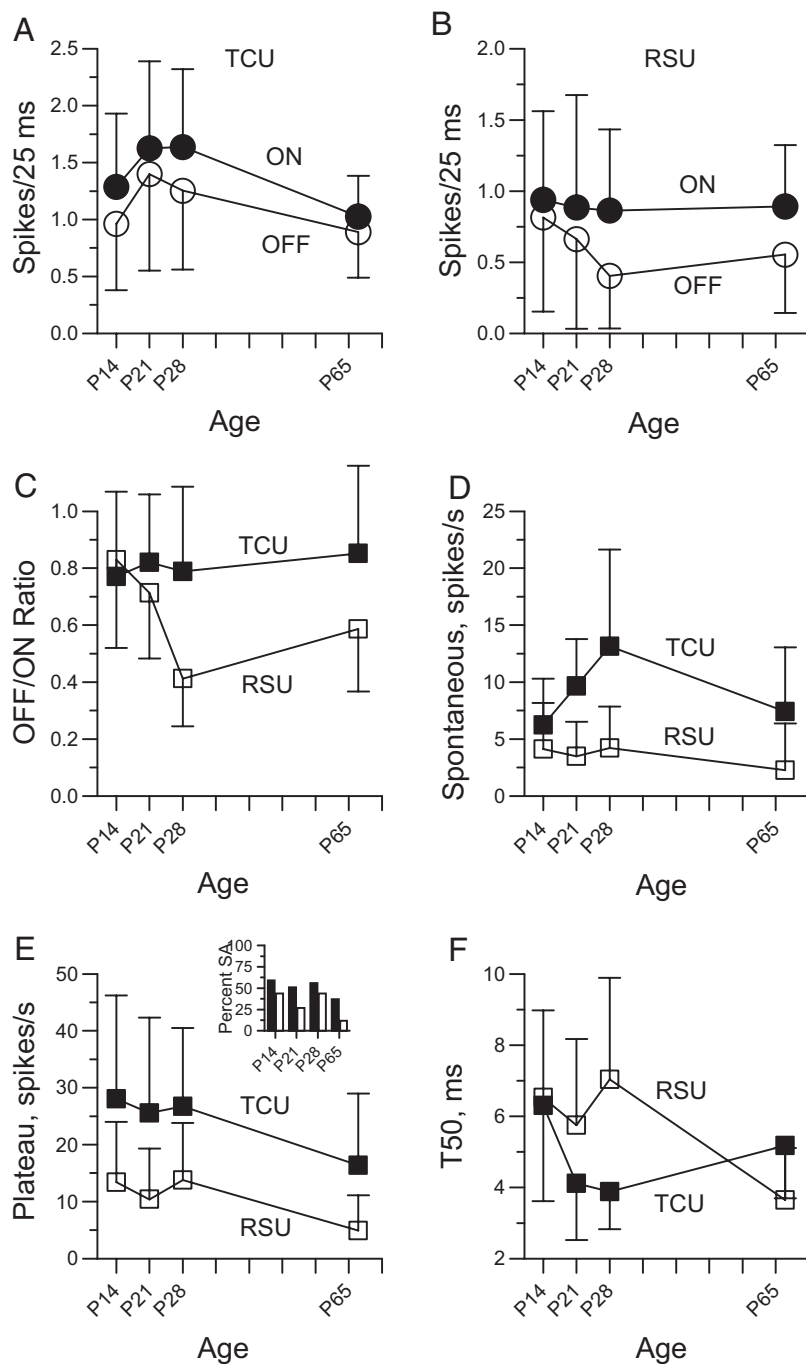

FIG. 2. Development of response magnitudes and temporal dispersion among TCUs and RSUs. *A*: magnitudes of TCU ON (●) and OFF (○) change in parallel as a function of age. Responses are averaged over all deflection angles. *B*: RSU ON (●) response magnitudes remain constant, whereas OFF responses (○) decrease with age. Responses are averaged over all deflection angles. *C*: OFF-ON ratios of TCUs (■) and RSUs (□) diverge during development. *D*: development of spontaneous firing rates in TCUs (■) and RSUs (□) follow different trajectories. Firing rates, in hertz, are derived from a 100-ms epoch before whisker deflection onset. *E*: plateau firing rates in response to sustained whisker deflections among TCUs and RSUs decrease with age. Firing rates, in hertz, are calculated from a 100-ms window during the latter 100 ms of the hold portion of the ramp-and-hold stimulus. *Inset*: proportion of slowly adapting neurons among TCUs (filled bars) and RSUs (hollow bars). *F*: development of time to 50th percentile spike (T50) during the ON response for TCUs (■) and RSUs (□). All data are shown as 0.05 – trimmed mean \pm SD. SD bars are plotted in 1 direction for clarity.

ON responses are maintained at ~ 0.9 spike/stimulus during development and into adulthood (0.94 ± 0.62 in P14 animals and 0.89 ± 0.43 in P65 animals; KW, $P = 0.39$). However, cortical OFF responses decrease during the same time period from 0.81 ± 0.66 to 0.55 ± 0.41 spikes/stimulus (KW, $P = 0.03$). The age-dependent decrease in OFF response magnitude among RSUs gives rise to the thalamocortical OFF response transformation observed in adult animals such that OFF-ON ratios are larger in the thalamus than in the cortex (Kyriazi et al. 1994; Simons and Carvell 1989). As shown in Fig. 2C, OFF-ON ratios of ~ 0.8 are similar among cortical and thalamic neurons at P14. The average OFF-ON ratio of RSUs decreases sharply after P14 to 0.41 ± 0.17 at P28 and increases some-

what to the adult value of 0.59 ± 0.22 (KW, $P < 0.0001$). The average OFF-ON ratio among TCUs remains unchanged between P14 and adulthood (ANOVA, $P = 0.45$). Thus the thalamocortical OFF response transformation, thought to reflect the sensitivity of barrel circuitry to thalamic input timing (see DISCUSSION), matures after P14 primarily because of an age-dependent decrease in the magnitude of cortical OFF responses.

Spontaneous firing rates of thalamic and cortical neurons also undergo developmental changes. As shown in Fig. 2D, spontaneous firing of thalamic neurons initially increases between P14 and P28 from 6.2 ± 4.1 to 13 ± 8.5 spikes/s and decreases between P28 and P65 to 7.4 ± 5.6 spikes/s (KW, $P < 0.0001$). The aforementioned age-dependent changes in

VPM ON and OFF response magnitudes remain statistically significant when adjusted for spontaneous activity (data not shown). In contrast to thalamic spontaneous activity, spontaneous firing rates among cortical neurons decrease steadily, from 4.1 ± 4.1 spikes/s in P14 animals to 2.3 ± 4.1 spikes/s in adult rats (KW, $P = 0.00002$). Thus the increase in spontaneous firing among thalamocortical neurons between P14 and P28 is not reflected in the spontaneous firing of barrel RSUs, although spontaneous subthreshold activity increases during this time (Borgdorff et al. 2007).

Figure 2E shows average firing rates of thalamic and cortical neurons during sustained whisker deflection at the maximally effective angle, i.e., plateau responses, at different ages. Plateau activity of both TCUs and RSUs decreases significantly with age (KW, both $P < 0.0001$). The age-dependent decrease in plateau activity remains significant when adjusted for spontaneous firing rates at each age (data not shown). As a result of decreased plateau firing rates, the proportion of SA neurons (see METHODS), which maintain elevated firing rates in response to sustained whisker deflections, decreases both in the thalamus and in the cortex (Fig. 2E, inset; χ^2 , $df = 3$, $P = 0.02$ for TCU and $P = 0.001$ for RSU). Among TCUs, 59% are slowly adapting at P14 but only 37% at P65. Among RSUs, the proportion of slowly adapting units decreases from 44% at P14 to 12% in adulthood. As also shown previously in adult rats (Simons and Carvell 1989), in developing animals, plateau activity of TCUs is higher than that of RSUs.

Response timing

As suggested by the population PSTHs of Fig. 1, responses of individual units become more temporally focused during development. Figure 2F shows the average time required to discharge 50% of the spikes in the ON response (T50; see METHODS) as a function of age for thalamic and cortical neurons. Among TCUs, average T50 decreases sharply between P14 and P21, remains steady between P21 and P28, and increases slightly between P28 and adulthood (KW, $P < 0.0001$). Overall, by the end of the third postnatal week, one half of evoked spikes in the thalamic ON response occur within the first 4–5 ms. Maturation of T50 among RSUs follows a different trajectory than that of TCUs, remaining essentially unchanged between P14 and P28 and decreasing between P28 and P65 (KW, $P < 0.0001$). The apparently prolonged maturation of RSU T50 is consistent with the broad population ON response PSTHs seen at P14 through P28 in the cortex (see Fig. 1C). Temporal dispersion of the TCU OFF responses in adult animals is greater than that of VPM ON responses, and this

difference is thought to contribute to the thalamocortical OFF response transformation (Kyriazi and Simons 1993; Pinto et al. 2000). During development, T50 of TCU OFF responses decreases in parallel with that of ON responses from 10.9 ± 4.09 ms in P14 animals to 5.61 ± 1.94 ms in P65 rats (data not shown; KW, $P < 0.0001$). As in adult TCUs, OFF response T50 is larger than ON response T50 at all ages considered (data not shown; MW, $P < 0.015$).

During development, response latencies of thalamic and cortical neurons decrease but along different time-courses (Fig. 3). Mean TCU response latency decreases more than twofold between P14 and P65 from 14 ± 4.2 to 6.5 ± 0.8 ms (KW, $P < 0.0001$; Fig. 3A). The largest change occurs between P14 and P21. The average TCU response latency continues to decrease until P28, inasmuch as the latency at P21 still differs significantly from that at P65 (MW test with Bonferroni correction, $P < 0.0001$), whereas the latency at P28 does not (MW with Bonferroni correction, $P = 0.6$). TCU latencies also become more uniform during development. Figure 3B shows cumulative frequency histograms for thalamic response latencies. As is the case with mean TCU latency, the most pronounced changes in the distribution of latency values occur between P14 and P21, with the mature pattern emerging between P21 and P28 (Fig. 3B). Age-by-age comparisons confirm that the latency distribution at P21 differs from that at P65 (KS, $P < 0.003$ with Bonferroni correction), whereas the latency distribution at P28 is adult-like in shape (KS, $P > 0.3$ with Bonferroni correction).

Response latencies mature later in the cortex than in the thalamus. Cortical response latency decreases from 20 ± 3.9 in P14 pups to 7.4 ± 1.4 ms in adults (Fig. 3A). Maturation occurs in two major phases: RSU latencies decrease sharply between P14 and P21, plateau between P21 and P28, and decrease again between P28 and P65 (Fig. 3A). Although the first phase between P14 and P21 likely reflects changes in the thalamic input, the second phase between P28 and P65 likely occurs as a result of thalamocortical myelination (see DISCUSSION). Taken together, the latency and temporal dispersion measures indicate that cortical response timing continues to mature after the first month of life.

RSUs in P28 animals

Several units recorded in P28 animals displayed unusually prolonged ON responses and elevated plateau firing rates. The firing of these cells, which were recorded in multiple animals of this age group, was noticeably different from other cells in our sample from any age group. The long duration responses of

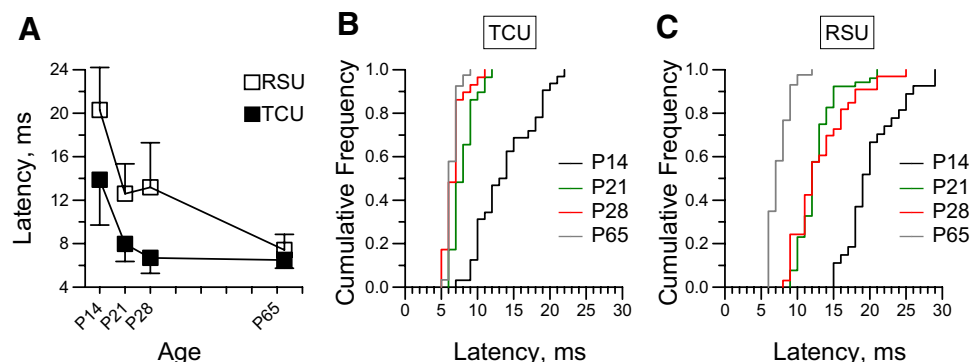

FIG. 3. Development of response latencies. A: mean response latency decreases with age for both TCUs (■) and RSUs (□) but with different time-courses. B: cumulative frequency histograms of TCU response latencies at different ages quantifying a major decrease toward adult-like values between P14 and P21. C: RSU response latencies mature in 2 distinct phases: between P14 and P21 and between P28 and P65.

these cells account for the slightly broadened shape of the population ON response PSTH in Fig. 1C, for the small, although not significant, increase in plateau activity in Fig. 2E and similarly for the increase in T50 values evident in Fig. 2F. Other neurons recorded in this age group displayed unremarkable response properties, suggesting that experimental variables, such as anesthesia, are unlikely to account for these observations.

Angular tuning

The maturation of angular tuning also differs between thalamic and cortical neurons. Figure 4A shows a quantitative measure of angular tuning computed as the ratio of the ON response magnitude in the maximally effective direction to the ON response averaged over all directions of whisker movement (ON_{max}/ON_{mean}); larger ON_{max}/ON_{mean} ratios indicate a higher degree of angular selectivity. ON_{max}/ON_{mean} ratios for thalamic neurons are largest at P14, decreasing to adult values during the next postnatal week (KW, $P = 0.0001$). In contrast, ON_{max}/ON_{mean} ratios of cortical neurons remain unchanged (KW, $P = 0.25$). Average polar plots of evoked ON responses at P14 and P65 are shown in Fig. 4, B and C. For these plots, individual unit responses at each deflection angle are normalized to the response at the maximally effective angle, rotated to a common arbitrary angle (downward), and averaged over the sampled population. For TCUs, ON responses at the angle opposite to the maximally effective one increase from P14 to P65. In contrast, the polar plots for RSUs, like the ON_{max}/ON_{mean} ratio, are virtually identical at P14 and P65. These data indicate that thalamic neurons become less angularly specific between P14 and P65, whereas cortical neurons maintain their angular specificity.

RF focus

During development, TCU RFs become larger and those of RSUs become more focused onto the PW. We compared responses evoked by the PW to those evoked by adjacent whisker deflections using a ratio of their ON response magnitudes; smaller AW/PW ratios indicate greater spatial focusing of the receptive field. For data plotted in Fig. 5A, AW/PW ratios are collapsed across all tested adjacent whiskers. For TCUs, the average AW/PW ratio increases from 0.17 ± 0.18 at

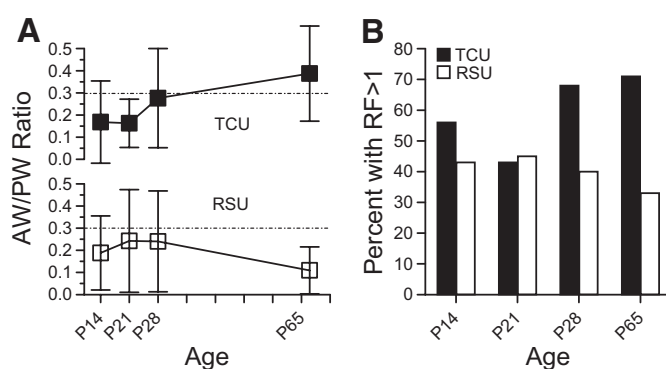

FIG. 5. Development of excitatory receptive fields. *A*: ratio of adjacent whisker-evoked to principal whisker-evoked ON responses among TCUs (*top*, ■) and RSUs (*bottom*, □) as a function of age. Both TCU and RSU adjacent whisker (AW)/principal whisker (PW) ratios are plotted on the same scale but separated for clarity. *B*: percent of TCUs (filled bars) and RSUs (open bars) having multiwhisker excitatory receptive fields (RFs > 1) as a function of age. Data are derived from neurons whose PW and all 4 AWs were tested: TCUs, P14 $n = 18$, P21 $n = 21$, P28 $n = 25$, P65 $n = 21$. For RSUs, P14 $n = 14$, P21 $n = 47$, P28 $n = 25$, and P65 $n = 33$.

P14 to 0.39 ± 0.22 at P65 (Fig. 5A, *top*; KW, $P < 0.0001$). Thus on average, the relative size of the AW response in TCUs increases twofold. The absolute magnitude of AW-evoked responses in TCUs also increases with age (data not shown; KW, $P < 0.0001$). In contrast, average AW/PW ratios among RSUs decrease with age (Fig. 5A, *bottom*; KW, $P < 0.0001$). Notably, AW/PW ratios are equivalent among TCUs and RSUs at P14, but diverge such that TCU values become larger, whereas RSU values decrease. Like the AW/PW ratio, the absolute magnitude of AW-evoked responses among RSUs declines with age (data not shown, KW, $P < 0.0001$).

We also examined the proportion of TCUs and RSUs that responded with statistically significant ON responses to at least one of four tested AWs (Fig. 5B; see METHODS). The percentage of TCUs having a multiwhisker response increases from 56% (10/18 units) at P14 to 71% (15/21 units) at P65 ($\chi^2 = 9.3$, $df = 3$, $P = 0.026$). The proportion of RSUs with multiwhisker RFs remains constant at 30–40% ($\chi^2 = 1.05$, $df = 3$, $P = 0.79$).

FSUs

We recorded from a small number of FSUs, presumed inhibitory interneurons, in P14 ($n = 4$) and P65 ($n = 7$)

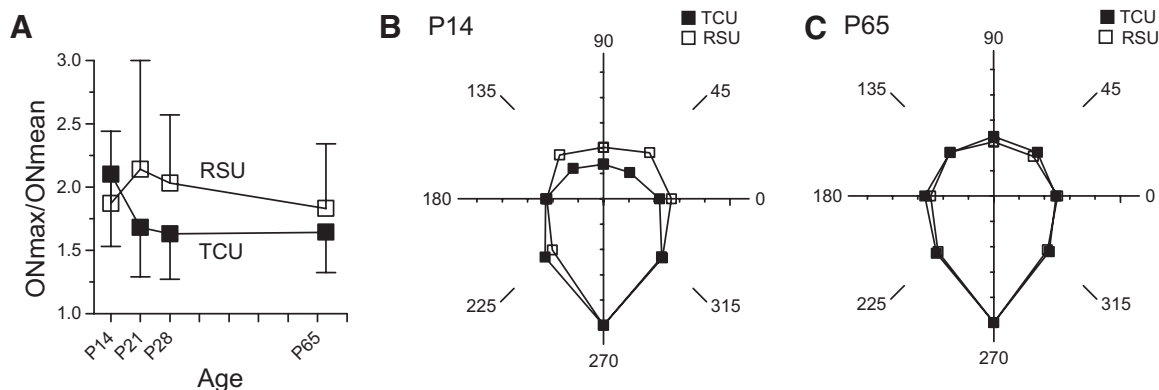

FIG. 4. Development of angular tuning. *A*: average ratio of ON response magnitude at the maximally effective angle to the magnitude averaged over all deflection angles (ON_{max}/ON_{mean}) for TCUs (■) and RSUs (□) as a function of age. *B*: normalized polar plots of TCU (■) and RSU responses (□) at P14. *C*: normalized polar plots of TCU and RSU responses at P65.

animals. Although the small sample size precludes robust quantitative analysis, qualitative review of the data suggests some interesting trends in FSU development (Fig. 6). Viewed in population PSTHs, suprathreshold responses of FSU's in P14 animals are strikingly single whisker, whereas those in adult rats show clear AW-evoked responses (Fig. 6A); the latter finding is consistent with data from larger samples of FSUs (Bruno and Simons 2002; Simons and Carvell 1989). OFF-ON ratios of fast-spike units seem to remain unchanged from P14 to P65 (Fig. 6B; Student's *t*-test, $P = 0.97$). In contrast, FSU AW/PW ratios are larger in adult compared with P14 animals (Fig. 6C; Mann-Whitney, $P = 0.005$). These findings in FSUs are thus qualitatively similar to those observed in TCUs.

DISCUSSION

Responses of thalamic barreloid and cortical barrel neurons to controlled whisker deflections were examined in 2-, 3-, and 4-wk-old and adult rats. To minimize nonspecific age-related variability, animals in all age groups were studied using the same surgical, anesthetic, and recording methods. Techniques essentially identical to those used previously in adult rats (Bruno and Simons 2002; Simons and Carvell 1989) were miniaturized for use in rat pups, and objective criteria were used to maintain comparable physiologic states in animals at different ages. Data obtained under identical conditions in equivalent age groups are available from trigeminal ganglion cells (Shoykhet et al. 2003). Taken together, results indicate that response timing and response magnitudes change throughout the whisker-to-barrel pathway through at least the end of the 4th postnatal week. Some functional changes parallel maturation of the input neurons, although others seem to reflect local processes maturing at different developmental stages.

Under our recording conditions, both thalamic and cortical neurons responded robustly to single whisker deflections and had definable RFs. This contrasts with an earlier study of cortical responses to whisker stimulation in P7 rats under urethane anesthesia (Armstrong-James 1975) in which cortical neurons responded only weakly and required very long intervals between sequential whisker stimuli to sustain suprathreshold responses. More recent *in vivo* cortical recordings in slightly older animals have shown, in agreement with these findings, that by P12–P14, cortical neurons show both sub- and

suprathreshold responses to stimulation of anatomically correct PW and AWs (Borgdorff et al. 2007; Bureau et al. 2004; Lendvai et al. 2000; Stern et al. 2001). Taken together with these findings, available evidence suggests robust changes in cortical function during the first 2 postnatal wk followed by a protracted period of refinement from the onset of whisking to early adulthood.

Axonal conduction and response timing

Thalamic response latencies mature primarily between P14 and P21, becoming adult-like by P28. At the same time, response latencies decrease in trigeminal ganglion cells, in roughly linear fashion, only by ~ 1.5 ms from P14 to P65 (Shoykhet et al. 2003). The larger latency decrease (~ 6 ms) among thalamic neurons likely reflects faster conduction in trigeminothalamic axons that transmit afferent activity to VPM via the principal sensory nucleus (PrV); in this regard, the medial longitudinal fasciculus, another brain stem projection pathway, attains an adult-like degree of myelination only toward P21 in the rat (Hamano et al. 1998).

Faster conduction velocities within a population of afferent fibers can lead to shorter time intervals between the arrival of spikes in any two axons if the variances within the population remain constant or actually decrease. A developmental increase in afferent conduction velocities would be likely to produce stronger temporal summation in TCUs. Perhaps as a result, PW-evoked spikes redistribute toward the early phase of TCU ON responses as indicated by smaller T50 values in older animals. Similarly, reductions in inter-spike arrival times may increase the effectiveness of weak responses, i.e., those consisting of relatively few spikes in two or more afferent axons. In adult PrV, responses to nonpreferred deflection angles and AW deflections are relatively weak (Minnery and Simons 2003). Developmental changes in trigeminothalamic conduction may thus account, at least in part, for our findings of broadened directional tuning and increased receptive field size during TCU development.

Response latencies of cortical neurons decrease in two stages. The first stage, from P14 to P28, roughly approximates decreases in TCU latencies, whereas during the second stage, between P28 and P65, cortical response latencies decrease with no further changes among TCUs. This finding suggests that

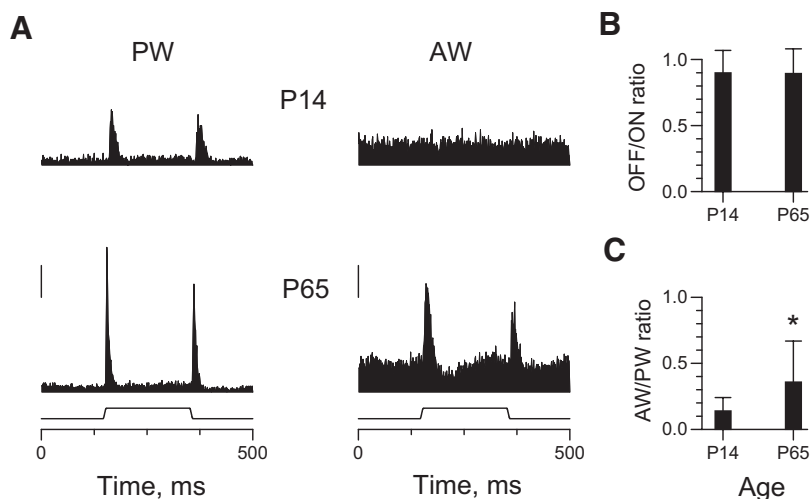

FIG. 6. Responses of fast spike units at P14 and P65. *A*: population PSTHs of fast-spike unit (FSU) responses to PW (left) and AW (right). Responses in P14 animals are in the top, and responses in P65 animals are in the bottom. PSTHs, in 1-ms bins, are based on responses accumulated over all deflection angles. The scale bar for PW-evoked responses on the bottom left indicates probability of observing a spike in a given 1-ms bin and has a value of 0.1. The scale for AW-evoked responses is on the bottom right and has a value of 0.02. The stimulus is indicated schematically below the PSTHs. *B*: OFF-ON ratio among FSUs at P14 and at P65. The data are plotted as mean \pm SD. *C*: AW/PW ratio among FSUs at P14 and at P65. Data are plotted as mean \pm SD. 0.05 – trimmed means were not used for FSU analyses because of small sample sizes. *Statistically significant difference between FSU AW/PW ratios at P14 vs. P65.

myelination of thalamocortical fibers continues beyond the 4th postnatal week and is consistent with a protracted developmental time course of cortical myelinogenesis in rats and other mammals, including humans (Norton and Poduslo 1973; Yakovlev and Lecours 1967). As in the case of the trigeminothalamic pathway, ongoing myelination of thalamocortical axons, by decreasing the variability of spike arrival times, may contribute to the pronounced temporal focusing of RSU responses that occurs between P28 and P65.

Development of response properties in VPM neurons

Among VPM neurons, PW-evoked responses to deflection onsets and offsets increase ~30% in magnitude between P14 and P21 and decrease to adult values between P28 and P65. In contrast, ON and OFF responses of primary afferent neurons in the trigeminal ganglion progressively increase in magnitude, approximately doubling between P14 and P65 (Shoykhet et al. 2003). Primary afferent input is thus attenuated centrally (Shoykhet et al. 2000), although, at least in the adult, this does not seem to occur in PrV, where whisker-evoked responses are considerably more robust (Minnery and Simons 2003). The maturation of PrV response properties is unknown, although available evidence indicates that PrV circuitry is largely mature by the second postnatal week in the rat (Guido et al. 1998; Leamey and Ho 1998). At the level of the thalamus, synaptic depression provides a potential mechanism for attenuating stimulus-evoked firing rates. Lemniscal synapses onto VPM neurons depress strongly at stimulation frequencies of >2 Hz in vitro (Castro-Alamancos 2002), even in slices taken from adult mice. In our recording conditions, spontaneous firing rates increase during development in the trigeminal ganglion (Shoykhet et al. 2003), in VPM (Fig. 2) and, by extension, in PrV. Thus immediately before stimulus onset, lemnisco-thalamic synapses might be more depressed in older versus younger rats. This mechanism could counteract the developmental increase in stimulus-evoked firing of primary afferent neurons.

Among VPM neurons, ON and OFF responses change in parallel, such that OFF-ON ratios remain constant; this contrasts with RSU responses wherein OFF-ON ratios decrease progressively from P14 to adulthood. In adult rats, TCU OFF responses and OFF-ON ratios are unexpectedly large compared with their inputs (Kyriazi et al. 1994; Minnery and Simons 2003). In our recording conditions, OFF response enhancement in thalamic neurons is thought to reflect engagement during some stimulus presentations of low-threshold T-type Ca^{2+} channels (Kyriazi et al. 1994). This finding that thalamic OFF-ON ratios are as large at P14 as at P65 suggests that T-type Ca^{2+} channels are mature at this time. Consistent with this interpretation, T-type Ca^{2+} channel-dependent burst firing patterns in VPM neurons become adult-like by P12 in the rat (Velazquez and Carlen 1996).

Between 2 wk of age and adulthood, directional tuning of TCUs becomes broader, and their RF size increases. These changes could reflect subtle maturational processes within VPM. First, dendrites of VPM neurons continue to increase in length well into the 3rd postnatal week (Warren and Jones 1997; Zantua et al. 1996), suggesting that, with age, VPM neurons may sample a greater number and/or variety of ascending inputs. Second, spontaneous inhibitory postsynaptic currents in VPM neurons are smaller, decay faster, and carry

less charge at P21 than at P14 (Huntsman and Huguenard 2000), suggesting that the level of tonic inhibition in VPM, mediated by RT neurons, may be developmentally regulated. Lower levels of tonic inhibition could result in the observed maturation of RF size and directional tuning by influencing the effective threshold for weak inputs such as those evoked by AW deflections or PW deflections in nonpreferred directions.

Development of thalamocortical response transformations

Response properties of barrel RSUs change, in some cases rather substantially, throughout a relatively long developmental period extending until at least the end of the 4th postnatal week. In a number of important respects, whisker-evoked responses in RSUs diverge from their thalamic input during development. First, PW-evoked OFF responses diminish in magnitude, whereas ON responses remain constant in size. Correspondingly, OFF-ON ratios of barrel RSUs, which at P14 are equivalent to those of TCUs, decrease with age. In contrast, OFF-ON ratios remain invariant in TCUs. Second, RSU ON response magnitudes are similar at all ages, whereas TCU ON response magnitudes increase from P14 to P21 and decrease by P65. Third, RSU spontaneous firing rates decrease from P14 to P65 despite overall increases in TCU firing rates. Fourth, RSUs maintain their degree of directional selectivity with age while thalamic neurons become slightly less tuned. Fifth and perhaps most interestingly, the absolute and relative magnitudes of AW-evoked responses in RSUs decrease with age; that is, RSU RFs become more spatially focused onto the PW, whereas thalamic neurons become progressively more multiwhisker.

In adults, thalamocortical response transformations are thought to reflect the combined effects of strong, rapid engagement of intrabarrel inhibition and neuronal nonlinearities (Pinto et al. 2000), especially in the spiking responses of RSUs, presumed excitatory barrel neurons. The latter may be enhanced by RSU-RSU connections, recurrent excitation being inherently nonlinear. Our albeit small sample of FSUs suggests that, in 2-wk-old animals, as in adults, inhibitory barrel neurons respond robustly and faithfully to their thalamic inputs. This conclusion is consistent with in vitro studies of immature barrel cortex showing that fast-spiking neurons are strongly engaged by monosynaptic thalamocortical input by the end of the first postnatal week (Cruikshank et al. 2007; Daw et al. 2007). Both excitatory and inhibitory connections within the barrel, although present during the first postnatal week (Agmon et al. 1996; Feldmeyer et al. 1999), are still maturing between 2 wk of age and adulthood (Blue and Parnavelas 1983a,b; Borgdorff et al. 2007; Land and Shamalla-Hannah 2002; White et al. 1997).

Developmentally regulated increases in intrabarrel inhibition could counteract the effects of increased TCU responsiveness and spontaneous activity, thereby limiting RSU spontaneous firing rates and ON response magnitudes. Increases in TCU spontaneous firing could also contribute by producing more synaptic depression at thalamocortical synapses and higher levels of FSU-mediated tonic inhibition. In addition, greater recurrent excitation caused by maturation of intrabarrel excitatory circuitry would enhance the nonlinear properties of the barrel circuit, rendering it more differentially responsive to preferred versus nonpreferred afferent inputs. Mature barrel circuitry is preferentially sensitive to the initial firing syn-

chrony evoked in thalamic neurons during the first few milliseconds of their response (Kyriazi and Simons 1993; Kyriazi et al. 1994; Pinto et al. 1996, 2000). Synchronously or near-synchronously arriving thalamic spikes are thought to engage barrel circuitry before its activity is suppressed by strong local inhibition. Thus maturation of intrabarrel inhibition would likely render barrel circuitry more differentially responsive to whisker stimuli that evoke synchronous versus temporally dispersed TCU firing.

At P14, a number of response properties (ON and OFF response magnitudes, OFF-ON and AW/PW ratios, time to 50th percentile spike) are equivalent, or nearly so, in RSUs and TCUs. It thus seems that at P14, neonatal barrel circuitry effects little change in the afferent signal. Adult-like differences between the response properties of TCUs and RSUs develop between 2 wk of age and adulthood. Interestingly, virtually all of the response properties displayed by neurons in P14 rats are similar to those observed in adult animals whose whiskers had been trimmed postnatally beginning either at birth or at 2 wk of age (Shoykhet et al. 2005; Simons and Land 1987a).

We propose that, during development, barrel circuits become increasingly sensitive to thalamic population firing synchrony. In young animals, thalamic OFF responses are more temporally dispersed than ON responses, and this persists through adulthood. If neonatal barrel circuitry was as sensitive to thalamic initial firing rates as adult circuitry, RSU OFF-ON ratios in young animals would be smaller than those of thalamic neurons. However, at P14, RSU and TCU OFF-ON ratios are equivalent; during the next few weeks, the RSU OFF response decreases the adult-like thalamocortical transformation emerges. The OFF response decrease cannot easily be accounted for by the preceding TCU plateau activity, because the latter actually decreases, likely producing less tonic inhibition and less thalamocortical synaptic depression. Increased sensitivity of barrel circuitry to thalamic response timing can similarly account for the decrease in RSU AW responses, inasmuch as the TCU population displays greater initial firing synchrony to PW versus AW deflections. A developmental increase in circuit timing sensitivity would result in progressively smaller RSU AW/PW ratios, despite a concurrent increase in the magnitude of thalamic AW responses. The constancy of RSU directional sensitivity despite TCU decreases might also be explained by this mechanism.

Our findings suggest that, in young animals, the responses of RSUs are determined more by the overall response magnitudes of TCUs than by their initial firing rates. In adults, RSUs are considerably more sensitive to the velocity of whisker deflection than to deflection amplitude (Pinto et al. 2000); among TCUs, velocity is encoded almost entirely by their initial firing rates, whereas differences in deflection amplitude are ambiguously encoded by initial firing rates and by overall response magnitudes. Thus an experimentally testable prediction is that barrel circuitry is more deflection-amplitude sensitive in young versus adult animals. If so, it would raise the possibility that behavioral discriminations of whisker deflection velocity and amplitude (Stuttgen et al. 2006) may differ in young versus adult rats.

ACKNOWLEDGMENTS

Present address of M. Shoykhet: Division of Pediatric Critical Care, 6th Floor Main Tower, Children's Hospital of Pittsburgh, Pittsburgh, PA 15213.

GRANTS

This work was supported by National Institute of Neurological Disorders and Stroke Grant NS-19950 to D. J. Simons. M. Shoykhet was supported in part by the Medical Scientist Training Program at the University of Pittsburgh School of Medicine.

REFERENCES

- Agmon A, Hollrigel G, O'Dowd DK.** Functional GABAergic synaptic connection in neonatal mouse barrel cortex. *J Neurosci* 16: 4684–4695, 1996.
- Armstrong-James M.** The functional status and columnar organization of single cells responding to cutaneous stimulation in neonatal rat somatosensory cortex S1. *J Physiol* 246: 501–538, 1975.
- Blue ME, Parnavelas JG.** The formation and maturation of synapses in the visual cortex of the rat. I. Qualitative analysis. *J Neurocytol* 12: 599–616, 1983a.
- Blue ME, Parnavelas JG.** The formation and maturation of synapses in the visual cortex of the rat. II. Quantitative analysis. *J Neurocytol* 12: 697–712, 1983b.
- Borgdorff AJ, Poulet JFA, Petersen CCH.** Facilitating sensory responses in developing mouse somatosensory barrel cortex. *J Neurophysiol* 97: 2992–3003, 2007.
- Brumberg JC, Pinto DJ, Simons DJ.** Cortical columnar processing in the rat whisker-to-barrel system. *J Neurophysiol* 82: 1808–1817, 1999.
- Bruno RM, Simons DJ.** Feedforward mechanisms of excitatory and inhibitory cortical receptive fields. *J Neurosci* 22: 10966–10975, 2002.
- Bureau I, Shepherd GM, Svoboda K.** Precise development of functional and anatomical columns in the neocortex. *Neuron* 42: 789–801, 2004.
- Carvell GE, Simons DJ.** Abnormal tactile experience early in life disrupts active touch. *J Neurosci* 15: 2750–2757, 1996.
- Castro-Alamancos MA.** Properties of primary sensory (lemniscal) synapses in the ventrobasal thalamus and the relay of high-frequency sensory inputs. *J Neurophysiol* 87: 946–953, 2002.
- Chiaia NL, Bauer WR, Rhoades RW.** Prenatal development of the receptive fields of individual trigeminal ganglion cells in the rat. *J Neurophysiol* 69: 1171–1180, 1993.
- Cruikshank SJ, Lewis TJ, Connors BW.** Synaptic basis for intense thalamocortical activation of feedforward inhibitory cells in neocortex. *Nat Neurosci* 10: 462–468, 2007.
- Curtiss S.** Developmental dissociations of language and cognition. In: *Exceptional Language and Linguistics*, edited by Opler LK and Menn L. New York: Academic Press, 1982, p. 285–312.
- Daw MI, Ashby MC, Isaac JTR.** Coordinated developmental recruitment of latent fast spiking interneurons in layer IV barrel cortex. *Nat Neurosci* 10: 453–461, 2007.
- Feldmeyer D, Egger V, Lubke J, Sakmann B.** Reliable synaptic connections between pairs of excitatory layer 4 neurones within a single 'barrel' of developing rat somatosensory cortex. *J Physiol* 521: 169–190, 1999.
- Fisher LD, van Belle G.** *Biostatistics: A Methodology for the Health Sciences*. New York: John Wiley, 1993.
- Guido W, Gunhan-Agar E, Erzurumlu RS.** Developmental changes in the electrophysiological properties of brain stem trigeminal neurons during pattern (barrelette) formation. *J Neurophysiol* 79: 1295–1306, 1998.
- Hamano K, Takeya T, Iwasaki N, Nakayama J, Ohto T, Okada Y.** A quantitative study of the progress of myelination in the rat central nervous system, using the immunohistochemical method for proteolipid protein. *Dev Brain Res* 108: 287–293, 1998.
- Harlow HF, Dodsworth RO, Harlow MK.** Total social isolation in monkeys. *Proc Natl Acad Sci USA* 54: 90–97, 1965.
- Hubel DH, Wiesel TN.** Receptive fields, binocular interaction and functional architecture in the cat's visual cortex. *J Physiol* 160: 106–154, 1962.
- Hubel DH, Wiesel TN, LeVay S.** Plasticity of ocular dominance columns in monkey striate cortex. *Philos Trans R Soc Lond B* 278: 377–409, 1977.
- Huntsman MM, Huguenard JR.** Nucleus-specific differences in GABA_A-receptor-mediated inhibition are enhanced during thalamic development. *J Neurophysiol* 83: 350–358, 2000.
- Kyriazi HT, Carvell GE, Simons DJ.** OFF response transformations in the whisker/barrel system. *J Neurophysiol* 72: 392–401, 1994.
- Kyriazi HT, Simons DJ.** Thalamocortical response transformations in simulated whisker barrels. *J Neurosci* 13: 1601–1615, 1993.

- Land PW, Shamalla-Hannah L.** Experience-dependent plasticity of zinc-containing cortical circuits during a critical period of postnatal development. *J Comp Neurol* 447: 43–56, 2002.
- Leamey CA, Ho SM.** Afferent arrival and onset of functional activity in the trigeminothalamic pathway of the rat. *Dev Brain Res* 105: 195–207, 1998.
- Lendvai B, Stern EA, Chen B, Svoboda K.** Experience-dependent plasticity of dendritic spines in the developing rat barrel cortex in vivo. *Nature* 404: 876–881, 2000.
- LeVay S, Wiesel TN, Hubel DH.** The development of ocular dominance columns in normal and visually deprived monkeys. *J Comp Neurol* 191: 1–51, 1980.
- McCandlish CA, Li CX, Waters RS.** Early development of the SI cortical barrel field representation in neonatal rats follows a lateral-to-medial gradient: an electrophysiological study. *Exp Brain Res* 92: 369–374, 1993.
- Minnery BS, Simons DJ.** Response properties of whisker-associated trigeminothalamic neurons in rat nucleus principalis. *J Neurophysiol* 89: 40–56, 2003.
- Norton WT, Poduslo SE.** Myelination in rat brain: changes in myelin composition during brain maturation. *J Neurochem* 21: 759–773, 1973.
- Pinto DJ, Brumberg JC, Simons DJ.** Circuit dynamics and coding strategies in rodent somatosensory cortex. *J Neurophysiol* 83: 1158–1166, 2000.
- Pinto DJ, Brumberg JC, Simons DJ, Ermentrout GB.** A quantitative population model of whisker barrels: re-examining the Wilson-Cowan equations. *J Comp Neurosci* 3: 247–264, 1996.
- Sherwood NM, Timiras PS.** *A Stereotaxic Atlas of the Developing Rat Brain*. Los Angeles, CA: University of California, 1970.
- Shoykhet M, Doherty D, Simons DJ.** Coding of deflection velocity and amplitude by whisker primary afferent neurons: implications for higher level processing. *Somatosens Mot Res* 17: 171–180, 2000.
- Shoykhet M, Land PW, Simons DJ.** Whisker trimming begun at birth or on postnatal day 12 affects excitatory and inhibitory receptive fields of layer IV barrel neurons. *J Neurophysiol* 94: 3987–3995, 2005.
- Shoykhet M, Shetty P, Minnery BS, Simons DJ.** Protracted development of responses to whisker deflection in rat trigeminal ganglion neurons. *J Neurophysiol* 90: 1432–1437, 2003.
- Siegel S.** *Non-Parametric Statistics for the Behavioral Sciences*. New York: McGraw-Hill, 1956.
- Simons DJ.** Multi-whisker stimulation and its effects on vibrissa units in rat Sml barrel cortex. *Brain Res* 276: 178–182, 1983.
- Simons DJ, Carvell GE.** Thalamocortical response transformations in the rat vibrissa/barrel system. *J Neurophysiol* 61: 311–330, 1989.
- Simons DJ, Land PW.** Early experience of tactile stimulation influences organization of somatic sensory cortex. *Nature* 326: 694–697, 1987a.
- Simons DJ, Land PW.** A reliable technique for marking the location of extracellular recording sites using glass micropipettes. *Neurosci Lett* 81: 100–104, 1987b.
- Simons DJ, Land PW.** Neonatal whisker trimming produces greater effects in nondeprived than deprived thalamic barreloids. *J Neurophysiol* 72: 1434–1437, 1994.
- Stern EA, Maravall M, Svoboda K.** Rapid development and plasticity of layer 2/3 maps in rat barrel cortex in vivo. *Neuron* 31: 305–315, 2001.
- Stuttgen MC, Ruter J, Schwarz C.** Two psychophysical channels of whisker deflection in rats align with two neuronal classes of primary afferents. *J Neurosci* 26: 7933–7941, 2006.
- Van der Loos H, Woolsey TA.** Somatosensory cortex: structural alterations following early injury to sense organs. *Science* 179: 345–398, 1973.
- Velazquez JLP, Carlen PL.** Development of firing patterns and electrical properties in neurons of the rat ventrobasal thalamus. *Dev Brain Res* 91: 164–170, 1996.
- von Senden M.** *Space and Sight*. Glencoe, IL: Free Press, 1960.
- Warren RA, Jones EG.** Maturation of neuronal form and function in a mouse thalamo-cortical circuit. *J Neurosci* 17: 277–295, 1997.
- White EL, Weinfeld L, Lev DL.** A survey of morphogenesis during the early postnatal period in PMBSF barrels of mouse Sml cortex with emphasis on barrel D4. *Somatosens Mot Res* 14: 34–55, 1997.
- Wiesel TN, Hubel DH.** Single-cell responses in striate cortex of kittens deprived of vision in one eye. *J Neurophysiol* 26: 1003–1017, 1963.
- Wong-Riley MTT, Merzenich MM, Leake PA.** Changes in endogenous enzymatic reactivity to DAB induced by neuronal inactivity. *Brain Res* 141: 185–192, 1978.
- Yakovlev PI, Lecours AR.** The myelogenetic cycles of regional maturation in the brain. In: *Regional Development of the Brain in Early Life*, edited by Minkowski A. Oxford, UK: Blackwell Scientific, 1967, p. 3–70.
- Zantua JB, Wasserstrom SP, Arends J, Jacquin MF, Woolsey TA.** Postnatal development of mouse “whisker” thalamus: ventroposterior medial nucleus (VPM), barreloids, and their thalamocortical relay neurons. *Somatosens Mot Res* 13: 307–322, 1996.